

ADVANCED DC-DC CONVERTER CONTROLLED SPEED REGULATION OF INDUCTION MOTOR USING PI CONTROLLER

P.Elangovan¹, Dr.C.Kumar²,B.Gomathy³

SKP Engineering College, Tiruvannamalai.

elangoeee2007@gmail.com drchkumararima@gmail.com , gomathyee2012@gmail.com

ABSTRACT

This paper proposes the speed control of Induction motor using an advanced DC-DC Converter called positive output super lift Luo converter circuit. In the traditional method, the input of the inverter is derived from buck, boost or buck-boost converter which has the limitation over the DC link voltage level and complexity of control circuit. The proposed method uses positive output super lift Luo converter at the front end which boost up the DC link voltage level in a wide range and also the control only in the DC-DC converter instead of Inverter which leads to prevention of Electromagnetic torque ripple and Common mode voltage stress. Super-lift Luo-converters are popular for high output voltage application for years. They have very high voltage transfer gains in geometric progression on stage-by-stage. The proposed system uses PI controller which is highly preferable for industrial applications The simulation is conceded out by MATLAB/SIMULINK software.

Keywords : Elementary circuit, Induction motor, Luo Converter, PI controller, Voltage Source Inverter

1. INTRODUCTION

Sensor-less control of induction motor drives shows recent development for high performance industrial application [1]. Such control trim downs cost of the drive, size, and maintenance requirements by holding good system reliability and robustness. However, parameter sensitivity, high computational effort, and stability at low and zero speeds can be the main shortcomings of sensor-less control. Much recent research effort is focused on extending the operating region of sensor-less drives near zero stator frequency [2], [3]. Several solutions for sensor-less control of induction motor drives have been proposed based on the machine fundamental excitation model and high frequency signal injection methods, as summarized recently [1]. Fundamental model-based strategies use the instantaneous values of stator voltages and currents to estimate the flux linkage and motor speed. Various techniques have been suggested, such as model reference adaptive system (MRAS), Luenberger and Kalman-filter observers, sliding-mode observers, and artificial intelligence techniques. MRAS schemes offer simpler implementation and require less computational effort compared to other methods and are therefore the most popular strategies used for sensor-less control [3], [4].

However, the methods used in the literature [1] – [4] use the feedback signal to control the gating pulses of Voltage Source Inverter (VSI). In VSI both voltage and frequency at the output are varied to achieve speed control under v/f control to maintain high torque capability at all frequencies. The ratio v/f is chosen corresponding to the rated voltage and frequency. In PWM inverters, amplitude of fundamental output voltage is directly proportional to the modulation index 'm' [5]. Since the control circuit to provide gate pulse for VSI increases complexity.

DC-DC conversion technology has been developing very rapidly, and DC-DC converters have been widely used in industrial applications such as dc motor drives, computer systems and communication equipments. The output voltage of pulse width modulation (PWM) based DC-DC converters can be changed by changing the duty cycle. The positive output elementary super lift Luo converter is a new series of DC-DC converters possessing high-voltage transfer gain, high power density; high efficiency, reduced ripple voltage and current [6]. These converters are widely used in computer peripheral equipment, industrial applications and switch mode power supply, especially for high voltage-voltage

projects [6]-[7]. Control for them needs to be studied for the future application of these good topologies.

The super-lift technique considerably increases the voltage transfer gain stage by stage in geometric progression [8]-[9]. However, their circuits are complex. An approach, positive output elementary super lift Luo converters, that implements the output voltage increasing in geometric progression with a simple structured have been introduced. These converters also effectively enhance the voltage transfer gain in power-law terms [6].

Due to the time variations and switching nature of the power converters, their static and dynamic behavior becomes highly non-linear. The design of high performance control for them is a challenge for both the control engineering engineers and power electronics engineers. In general, a good control for DC-DC converters always ensures stability in arbitrary operating condition. Moreover, good response in terms of rejection of load variations, input voltage variations and even parameter uncertainties is also required for a typical control scheme. The static and dynamic characteristics of these converters have been well discussed in the literature [10].

The PI control technique offers several advantages compared to PID control methods and they are stability, even for large line and load variations, reduce the steady error, robustness, good dynamic response and simple implementation.

In this paper, state-space model for positive output elementary super lift Luo converter (POESLLC) are derived at first. A PI control is designed to control the gate signal of POESLLC with the help of induction motor reference speed. The performance of the system with PI control for positive output elementary super lift Luo converter is studied in Matlab/Simulink. Details on operation, analysis, control strategy and simulation results for positive output elementary super lift Luo converter (POESLLC) - VSI controlled Induction motor are presented in the subsequent sections.

2. MATHEMATICAL MODELING OF INDUCTION MOTOR

In the control of any power electronics drive system to start with a mathematical model of the plant is required. To design any type of controller to control the process of the plant mathematical model is required. The mathematical modeling of induction motor and the power circuit of the 3-φ induction motor is shown in the Fig. 1.

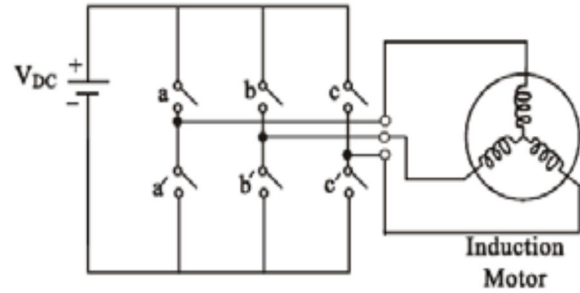

Figure. 1: Power circuit of induction motor

The equivalent circuit used for obtaining the mathematical model of the induction motor is shown in the Fig. 2.

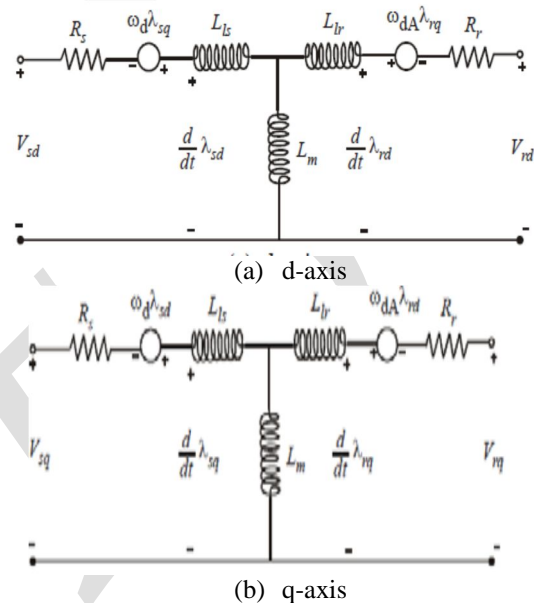

Figure. 2: Equivalent circuit of induction motor in d-q frame

The induction motor model is established using a rotating (*d*, *q*) field reference (without saturation) concept. An induction motor model is then used to predict the voltage required to drive the flux and torque to the demanded values within a fixed time period. This calculated voltage is then synthesized using the space vector modulation:

$$V_{sd} = R_s i_{sd} + \frac{d}{dt} \lambda_{sd} - \omega_d \lambda_{sq} \dots\dots\dots (1)$$

$$V_{sq} = R_s i_{sq} + \frac{d}{dt} \lambda_{sq} - \omega_d \lambda_{sd} \dots\dots\dots (2)$$

$$V_{rd} = R_r i_{rd} + \frac{d}{dt} \lambda_{rd} - \omega_{dA} \lambda_{rq} \dots\dots\dots (3)$$

$$V_{rq} = R_r i_{rq} + \frac{d}{dt} \lambda_{rq} - \omega_{dA} \lambda_{rd} \dots\dots\dots (4)$$

V_{sd} and V_{sq} , V_{rd} and V_{rq} are the direct axes and quadrature axes stator and rotor voltages. The flux linkages to the currents are given by the Eq. (5):

$$\begin{bmatrix} \lambda_{sd} \\ \lambda_{sq} \\ \lambda_{rd} \\ \lambda_{rq} \end{bmatrix} = M \begin{bmatrix} i_{sd} \\ i_{sq} \\ i_{rd} \\ i_{rq} \end{bmatrix}; M = \begin{bmatrix} L_s & 0 & L_m & 0 \\ 0 & L_s & 0 & L_m \\ L_m & 0 & L_r & 0 \\ 0 & L_m & 0 & L_r \end{bmatrix} \dots\dots\dots (5)$$

The electrical part of an induction motor can thus be described, by combining the above equations we get Eq. (6):

$$\begin{bmatrix} i_{sd} \\ i_{sq} \\ i_{rd} \\ i_{rq} \end{bmatrix} = \frac{1}{L_m^2 - L_r L_s} \times \left(\begin{bmatrix} i_{sd} \\ i_{sq} \\ i_{rd} \\ i_{rq} \end{bmatrix} + \begin{bmatrix} L_s & 0 & L_m & 0 \\ 0 & L_r & 0 & L_m \\ L_m & 0 & L_r & 0 \\ 0 & L_m & 0 & L_r \end{bmatrix} \begin{bmatrix} V_{sd} \\ V_{sq} \\ V_{rd} \\ V_{rq} \end{bmatrix} \right) \dots\dots\dots (6)$$

where, A is given by:

$$A = \begin{bmatrix} L_r R_s & \omega_{dA} L_m^2 - \omega_s L_r L_s & & \\ -(\omega_{dA} L_m^2 - \omega_s L_r L_s) & L_r R_s & & \\ -L_m R_s & L_s L_m (\omega_s - \omega_{dA}) & & \\ -L_s L_m (\omega_s - \omega_{dA}) & -L_m R_s & & \\ & -L_m R_r & -L_r L_m (\omega_s - \omega_{dA}) & \\ L_r L_m (\omega_s - \omega_{dA}) & -L_m R_r & & \\ L_s R_r & \omega_s L_m^2 - \omega_{dA} L_r L_s & & \\ -(\omega_s L_m^2 - \omega_{dA} L_r L_s) & L_s R_r & & \end{bmatrix} \dots\dots\dots (7)$$

The instantaneous torque produced is given by:

$$T_{em} = \frac{P}{2} (\lambda_{rq} i_{rd} - \lambda_{rd} i_{rq}) \dots\dots\dots (8)$$

The electromagnetic torque expressed in terms of inductances is given by:

$$T_{em} = \frac{P}{2} L_m (i_{sq} i_{rd} - i_{sd} i_{rq}) \dots\dots\dots (9)$$

The mechanical part of the motor is modeled by the equation:

$$\frac{d}{dt} \omega_{Mech} = \frac{T_{em} - T_L}{J_{eq}} = \frac{P}{2} L_m \frac{(i_{sq} i_{rd} - i_{sd} i_{rq}) - T_L}{J_{eq}} \dots\dots\dots (10)$$

3. POSITIVE OUTPUT ELEMENTARY SUPER LIFT LUO CONVERTER

For the purpose of optimize the stability of positive output elementary super lift Luo converter dynamics, while ensuring correct operation in any working condition, a PI control is a more feasible approach.

The PI control has been presented as a good alternative to the control of switching power converters [11]. The main advantage PI control schemes is its insusceptibility to plant/system parameter variations that leads to invariant dynamics and static response in the ideal case.

The positive output elementary super lift Luo converter is shown in Fig. 3. It includes dc supply voltage V_{in} , capacitors C_1 and C_2 , inductor L_1 , power switch (n-channel MOSFET) S , freewheeling diodes D_1 and D_2 and load resistance R .

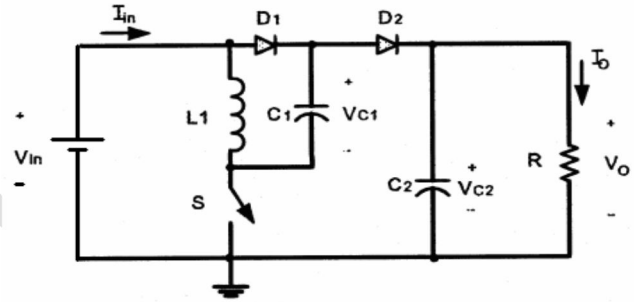

Figure. 3 The positive output elementary super lift Luo converter

The principle of the sliding mode controller is to make the capacitor voltages V_{C1} and V_{C2} follow as faithfully as possible capacitor voltage references. In the description of the converter operation, it is assumed that all the components are ideal and also the positive output elementary super lift Luo converter operates in a continuous conduction mode. Figs. 4 and 5 show the modes of operation of the converter.

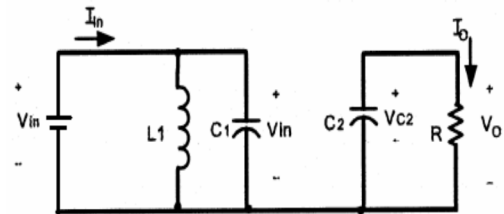

Fig. 4 Mode 1 operation

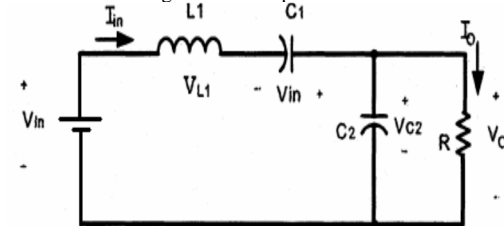

Figure. 5 Mode 2 operation

In Fig. 4 when the switch S is closed, voltage across capacitor C_1 is charged to V_{in} . The current i_{L1} flowing through inductor L_1 increases with voltage V_{in} . In Fig. 5 when the switch S is closed, decreases with voltage $(V_o - 2 V_{in})$. Therefore, the ripple of the inductor current i_{L1}

$$\Delta_{i_{L1}} = \frac{V_m}{L_1} dT = \frac{V_o - 2V_m}{L_1} dT \dots\dots\dots (11)$$

$$V_o = \frac{2-d}{1-d} V_m \dots\dots\dots (12)$$

The voltage transfer gain is

$$G = \frac{V_o}{V_m} = \frac{2-d}{1-d} \dots\dots\dots (13)$$

The input current i_m is equal to $(i_{L1} + i_{C1})$ during switching on and only equal to i_{L1} during switching-off. Capacitor current i_{C1} is equal to i_{L1} during switching-off. In steady state, the average charges across capacitor C_1 should not change. We have the following relations:

$$i_{m-off} = i_{L1-off} = i_{C1-off}, i_{m-on} = i_{L1-on} + i_{C1-on}$$

$$dT i_{C1-on} = (1-d)Ti_{C1-off}$$

If inductance L_1 is large enough, i_{L1} is nearly equal to its average current i_{L1} . Therefore

$$i_{m-off} = i_{L1} = i_{C1-off}, i_{m-on} = i_{L1} + \frac{1-d}{d} i_{L1}$$

$$i_{C1-on} = \frac{(1-d)}{d} i_{L1}$$

and average input current

$$I_m = di_{m-on} + (1-d)i_{m-off} = i_{L1} + (1-d)i_{L1} = (2-d)i_{L1} \dots\dots\dots (14)$$

Considering $T = 1/f$ and

$$\frac{V_m}{I_m} = \left(\frac{(1-d)}{(2-d)} \right)^2 \frac{V_o}{I_o} = \left(\frac{(1-d)}{(2-d)} \right)^2 R$$

The variation ratio of inductor current i_{L1} is

$$\xi = \frac{\Delta_{i_{L1/2}}}{i_{L1}} = \frac{d(2-d)TV_m}{2L_1I_m} = \frac{d(1-d)^2}{2(2-d)} \frac{R}{fL_1} \dots\dots\dots (15)$$

The ripple voltage of output voltage V_o is

$$\Delta_{v_o} = \frac{\Delta Q}{C_2} = \frac{I_o(1-d)T}{C_2} = \frac{(1-d)}{fC_2} \frac{V_o}{R} \dots\dots\dots (16)$$

Therefore, the variation ratio of output voltage V_o is

$$\xi = \frac{\Delta_{v_o} / 2}{V_o} = \frac{(1-d)}{2RfC_2} \dots\dots\dots (17)$$

4. PI CONTROLLER DESIGN FOR THE PROPOSED SYSTEM

The PI control is designed to ensure the specifying desired nominal operating point for Positive output elementary super lift Luo converter, then regulating Positive output elementary super lift Luo converter, so that it stays very closer to the nominal operating point in the case of sudden

disturbances, set point variations, noise, modeling errors and components variations. The PI control settings proportional gain (Kp) and integral time (Ti) are designed using Zeigler – Nichols tuning method [12]-[13] by applying the step test to obtain S – shaped curve of step response of Positive output elementary super lift Luo converter as shown in Fig. 6

From the S-shaped curve of step response of Positive output elementary super lift Luo converter may be characterized by two constants, delay time $L = 0.005s$ and time constant $T = 0.052s$.

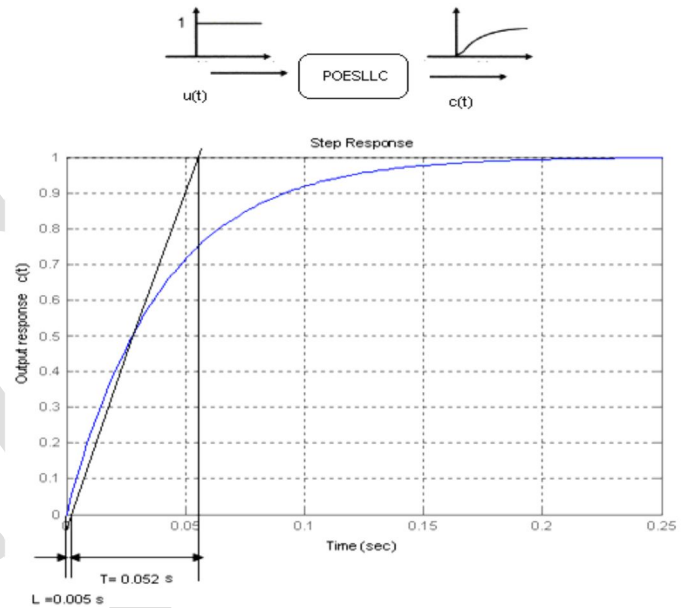

Figure.6 S- shaped curve of step response of Positive output elementary super lift Luo converter

The delay time and time constant are determined by drawing a tangent line at the inflection point of the S-shaped curve and determining the intersections of the tangent line with the time axis and line output response $c(t)$ as shown in Fig. 6. Ziegler and Nichols suggested to set the values of $Kp = 9.36$ and $Ti = 0.016s$.

5. SIMULATION

The validation of proposed system performance has been done using MATLAB/Simulink package with the parameter listed in Table-I.

Table 1 Parameters of proposed system

PARAMETER	RATING
Source Voltage	60V, DC
C1	20μF
C2	1000μF
L1	0.5mH
Inverter Switches	IGBT
Induction Motor	5HP, (430V-460V) AC, 60Hz, 1750RPM

The MATLAB/Simulink model for the proposed Positive output superlift Luo converter is shown in Fig.7. The simulink model for Positive output superlift Luo converter shows the simplicity in the design and the number of switches used is only one. Fig.8 shows the Input and Output Voltage of Positive output Super-lift Luo Converter. From the simulation result, it is very clear that for the given 60V DC, the proposed Positive output Super-lift Luo Converter produces the output voltage of 430V DC which shows that to drive a three phase Induction motor a minimum source can be utilized.

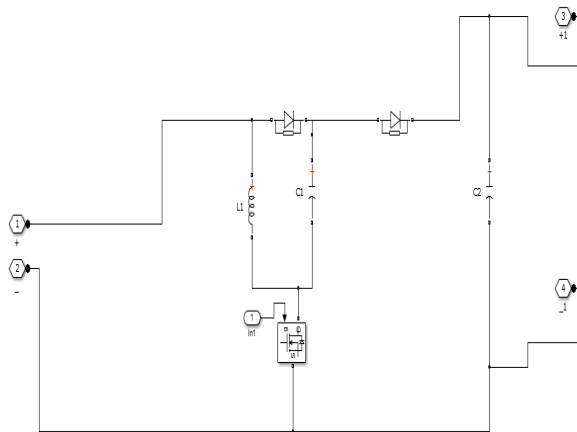

Figure.7 Simulink model of Positive output Super-lift Luo Converter

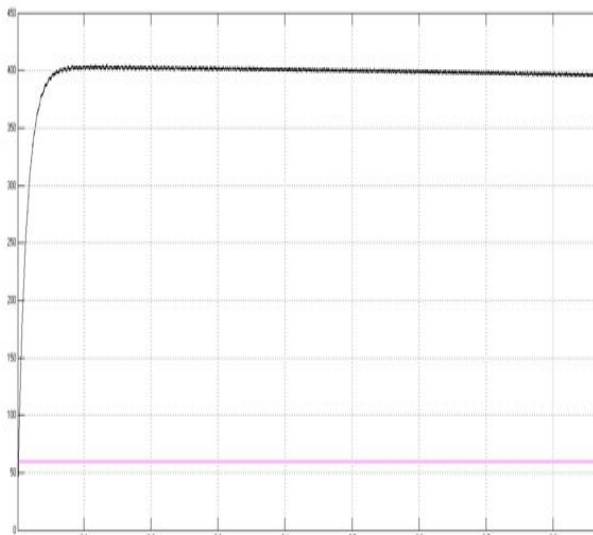

Figure.8 Input and Output Voltage of Positive Output Super-lift Luo Converter

The stator current of three phase induction motor is depicted in Fig.9. It can be seen that the high inrush current to the motor terminal has been vanished out within 0.5 seconds which adds one more advantage for the proposed system.

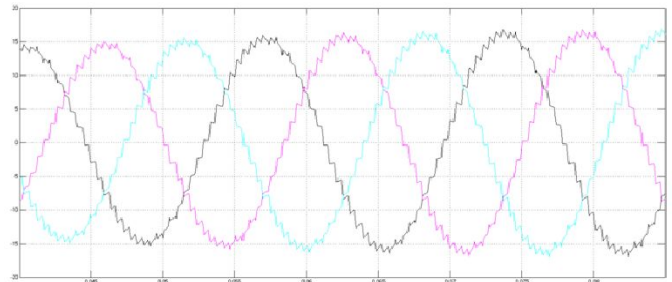

Figure.9 Stator Current of Three phase Induction Motor

Fig.10 and Fig.11 shows the speed response and the electromagnetic torque of three phase induction motor. The reference speed assigned to the three phase induction motor is 500 rpm. The motor speed has been regulated within a second.

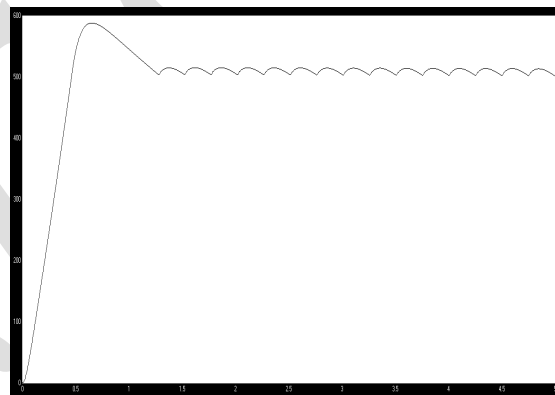

Figure.10 Speed Response of Three phase Induction Motor

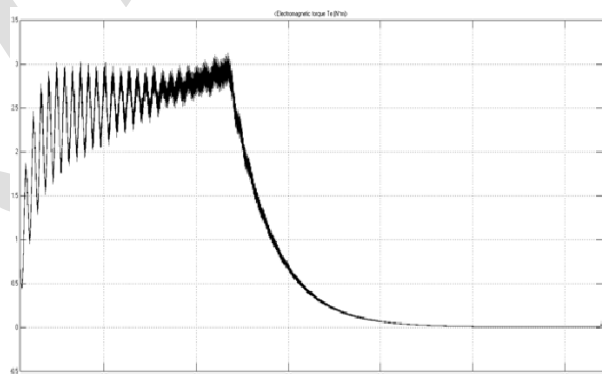

Figure.11 Electromagnetic Torque

6. CONCLUSION

The positive output elementary super lift Luo converter performs the voltage conversion from positive source voltage to positive load voltage. Due to the time variations and switching nature of the power converters, their dynamic behavior of the three phase induction motor becomes highly non-linear. This paper has successfully demonstrated the design, analysis, and suitability of PI controlled positive output elementary super lift Luo converter for speed regulation system of three phase induction motor. It is

suggested to implement any soft computing techniques for the gate control of Converter side.

REFERENCES

- [1] J. W. Finch and D. Giaouris, "Controlled AC electrical drives," *IEEE Trans. Ind. Electron.*, vol. 55, no. 2, pp. 481–491, Feb. 2008.
- [2] J. Holtz and J. Quan, "Drift and parameter compensated flux estimator for persistent zero stator frequency operation of sensorless controlled induction motors," *IEEE Trans. Ind. Appl.*, vol. 39, no. 4, pp. 1052–1060, Jul./Aug. 2003.
- [3] M. Rashed and A. F. Stronach, "A stable back-EMF MRAS-based sensorless low speed induction motor drive insensitive to stator resistance variation," *Proc. Inst. Elect. Eng.—Electr. Power Appl.*, vol. 151, no. 6, pp. 685–693, Nov. 2004.
- [4] V. Vasic and S. Vukosavic, "Robust MRAS-based algorithm for stator resistance and rotor speed identification," *IEEE Power Eng. Rev.*, vol. 21, no. 11, pp. 39–41, Nov. 2001.
- [5] B. K. Bose, "Adjustable Speed A. C. Drives—A Technology status Review", *IEEE Proceeding*, vol. 70, No. 2, PP. 116-135, 1982.
- [6] F.L.Luo and H.Ye, "Positive output super lift converters," *IEEE Transaction on power electronics*, Vol.18, No. 1, pp. 105-113, January 2003.
- [7] LUO F.L., "Luo converters – voltage lift technique," *Proceedings of the IEEE Power Electronics special conference IEEE-PESC'98*, Fukuoka, Japan, 17-22, pp. 1783-1789, May. 1998.
- [8] LUO F.L., "Luo converters – voltage lift technique (negative output)," *Proceedings of the second World Energy System international conference WES'98*, Toronto, Canada, 19-22, pp.253- 260, May. 1998.
- [9] LUO, F.L.: "Re-lift converter: design, test, simulation and stability analysis," *IEE Proc.Electr. Power Appl.*, 1998, 145, (4), pp. 315-325.
- [10] R.Middlebrook and S.Cuk, "A General Unified Approach to Modeling Switching-Converter Power Stages," *International Journal of Electronics*, Vol.42, No.6, pp. 521-550, June. 1977.
- [11] M. Namnabat, M. Bayati Poodeh, S. Eshtehardiha, "Comparison the control methods in improvement the performance of the DC-DC Converter," *The 7th International Conference on Power Electronics*. October 2007, pp. 246-251.
- [12] P. Comines and N. Munro, "PID controllers: recent tuning methods and design to specification", in *IEEE Proc. Control Theory Application*, vol.149, no.1, pp.46-53, Jan 2002.
- [13] Katsuhiko Ogata, "Modern Control Engineering," Published by Prentice – Hall of India Private Limited, New Delhi, Third Edition.